



SERIES 3200G | MERCROID® BY DWYER



EXPLOSION-PROOF PRESSURE TRANSMITTER

HART®, Push-Button Configuration, Rangeability (100:1)

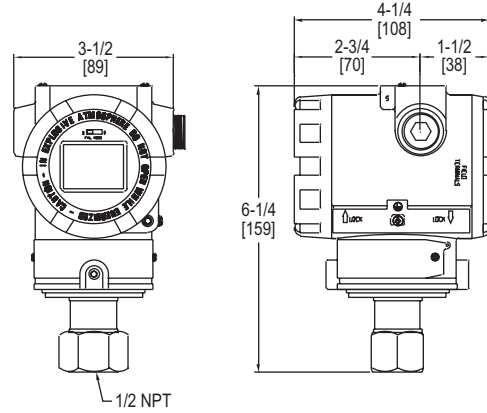

The Mercoid® Series 3200G Explosion-Proof Smart Pressure Transmitter is a microprocessor-based high performance transmitter, which has flexible pressure calibration, push-button configuration, and programmable using HART® Communication. The Series 3200G is capable of being configured with the zero and span buttons, a field calibrator is not required for configuration. The transmitter software compensates for thermal effects, improving performance. EEPROM stores configuration settings and stores sensor correction coefficients in the event of shutdowns or power loss. The Series 3200G is FM approved for use in hazardous (Classified) locations. The 100:1 rangeability allows the smart transmitter to be configured to fit any application.

FEATURES/BENEFITS

- Completely configurable using zero/span buttons (no calibrator required)
- Rangeability (100:1)
- High accuracy ($\pm 0.075\%$)
- Automatic sensor temperature compensation
- Fail-mode process function

APPLICATIONS

- Water and wastewater
- Chemical and petrochemical
- Pulp and paper
- Oil and gas
- Food and beverage

SPECIFICATIONS

Service: Compatible gases, steam, liquids or vapors.
Wetted Materials: 316L SS.
Accuracy: $\pm 0.075\%$ FS (@ 20°C).
Rangeability: 100:1 turn down.
Stability: $\pm 0.125\%$ FSO/yr.
Temperature Limits: Process: -40 to 248°F (-40 to 120°C); Ambient: Without LCD -40 to 185°F (-40 to 85°C); With LCD -22 to 176°F (-30 to 80°C).
Thermal Effect: $\pm 0.125\%$ span/32°C.
Power Requirements: 11.9 to 45 VDC.
Output Signal: 4 to 20 mA / HART® Communication.
Response Time: 0.12 s.
Damping Time: 0.25 to 60 s.
Loop Resistance: Operation: 0 to 1500 Ω ; HART® Communication: 250 to 500 Ω .
Electrical Connection: Two 1/2" female NPT conduit, screw terminal.
Process Connections: 1/2" female NPT.
Display: Optional 5 digit LCD.
Enclosure Rating: NEMA 4X (IP66) and explosion proof for Class I, Div I Groups A, B, C and D.
Weight: 5.5 lb (2.5 kg).
Agency Approvals: ATEX, CE, FM.

MODEL CHART

Model	Range psi (kPa)	Calibrated Span (Min. to Max.) psi (kPa)	Max. Pressure psi (bar)	LCD Display
3200G-1-FM-1-1	-14.5 to 21 (-100 to 150)	0.22 to 21 (1.5 to 150)	58 (4)	No
3200G-2-FM-1-1	-14.5 to 217 (-100 to 1500)	2 to 217 (15 to 1500)	580 (40)	No
3200G-3-FM-1-1	0 to 725 (0 to 5000)	7.25 to 725 (50 to 5000)	2000 (138)	No
3200G-4-FM-1-1	0 to 3600 (0 to 25000)	36 to 3600 (250 to 25000)	10000 (690)	No
3200G-5-FM-1-1	0 to 8500 (0 to 60000)	87 to 8700 (600 to 60000)	11600 (800)	No
3200G-1-FM-1-1-LCD	-14.5 to 21 (-100 to 150)	0.22 to 21 (1.5 to 150)	58 (4)	Yes
3200G-2-FM-1-1-LCD	-14.5 to 217 (-100 to 1500)	2 to 217 (15 to 1500)	580 (40)	Yes
3200G-3-FM-1-1-LCD	0 to 725 (0 to 5000)	7.25 to 725 (50 to 5000)	2000 (138)	Yes
3200G-4-FM-1-1-LCD	0 to 3600 (0 to 25000)	36 to 3600 (250 to 25000)	10000 (690)	Yes
3200G-5-FM-1-1-LCD	0 to 8500 (0 to 60000)	87 to 8700 (600 to 60000)	11600 (800)	Yes

Note: Contact factory for custom calibration.

ACCESSORIES

Model	Description
A-630	Stainless steel angle type bracket with SS bolts
A-631	Stainless steel flat type bracket with SS bolts
BBV-0N	2-valve block manifold
DevCom2000	HART® Communication Protocol Software

HART® is a registered trademark of Hart Communication Foundation.



SERIES 3200G | MERCROID® BY DWYER



EXPLOSION-PROOF PRESSURE TRANSMITTER

HART®, Push-Button Configuration, Rangeability (100:1)

MODEL CHART														
Example	3200G	-2	-FM	-3	-1	-LES	S2	A1	05	S	2	-05	-LCD	3200G-2-FM-3-1-LESS2A105S2-05-LCD
Series	3200G													Explosion-proof pressure transmitter
Range		1 2 3 4 5												-14.5 to 21 psig (factory set 0 to 21 psig) -14.5 to 217 psig (factory set 0 to 217 psig) 0 to 725 psig 0 to 3600 psig 0 to 8500 psig
Approval			FM ATEX WP											FM approved ATEX approved Weatherproof only (Only available with 316 SS housing)
Process Connection				1 3										1/2" female NPT Diaphragm seal
Electrical Connection					1									1/2" female NPT
Diaphragm Seal Type						LED LES LFD LFS								1 extended diaphragm seal direct mount 1 extended diaphragm seal capillary type high 1 flush diaphragm seal direct mount 1 flush diaphragm seal capillary type
Mounting Flange							S2 S3							2" (50 mm) 316L SS 3" (80 mm) 316L SS
Mounting Flange Rating								A1 A2 D1 D2 J1 J2						ANSI class 150# ANSI class 300# DIN PN 10/16 DIN PN 25/40 JIS 10 K JIS 20 K
Extension Length									00 05 10 15					No extension (standard for flush mount) 2" extension 4" extension 6" extension
Diaphragm Material										S P H T				316L SS diaphragm PTFE and 316L SS diaphragm Hastelloy C-276 diaphragm Tantalum diaphragm
Fill Fluid											2			Silicon oil (-40 to 400°F)
Capillary Length												XX		0 to 20 feet
Options													LCD SSH NIST CC	5 digit LCD 316 SS housing (only available with WP approval) NIST calibration Custom calibration

CUSTOM CALIBRATION VALUES	
Primary Units	in w.c., ft w.c., mm w.c., in Hg, psig, g/cm ² , kg/cm ² , Pa, kPa, bar, mbar, Torr, Atm, mm Hg
Upper Range Limit	20 mA value
Lower Range Limit	4 mA value
Damping Time	0 to 60 seconds
Display Mode	Primary unit, %, mA, rotate