

# GENERAL PURPOSE AND BAYONET TYPE THERMOCOUPLES & RTD'S

## GENERAL PURPOSE

## BAYONET

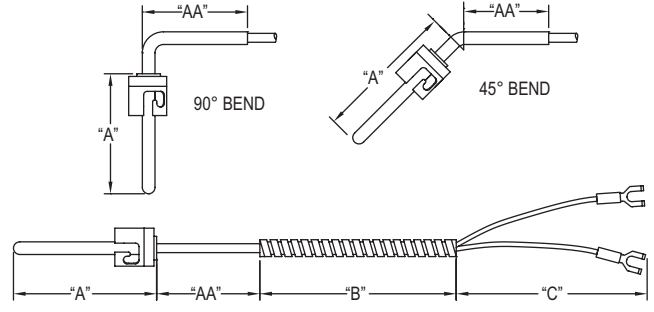
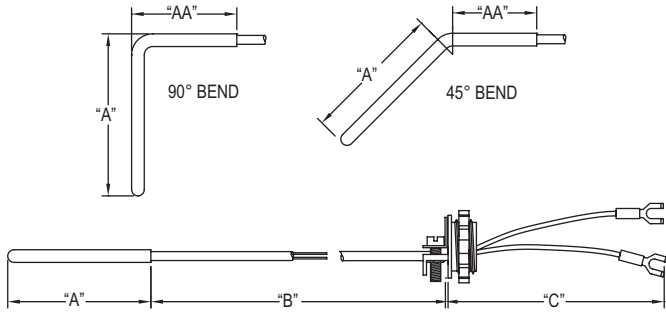

Series 4 & 5 General Purpose and Bayonet Type Thermocouples & RTD's tip temperatures can be as high as 842°F (450°C) for fiberglass insulated wire, and 392°F (200°C) for FEP insulated wire. Models can be specified with lead wires or head assembly construction. For higher temperatures see the Series R & 8 Mineral Insulated Probes. ●

### MODEL CODING

Fill in the appropriate numbers or letters to specify the probe of your choice. Fill in all boxes. If an item or dimension does not apply, fill those boxes with zeros '0'.

SENSOR TYPE				RTD TYPE				A			AA			B			C	
TYPE				TYPE				IN 1/10 INCH			IN 1/10 INCH			IN INCHES			IN INCHES	
6	100 Ω	RTD	0.00385 Ω/°C	2	2-Wire	Class B												
Z	1000 Ω	RTD	0.00385 Ω/°C	3	3-Wire	Class B												
4	100 Ω	RTD	0.00392 Ω/°C	5	2-Wire	Class A												
				6	3-Wire	Class A												

SENSOR TYPE	HARDWARE TYPE	EXTENSION TYPE	SENSOR TERMINALS	ELEMENTS	JUNCTION TYPE	SENSOR O.D.	BEND
J - T/C	1 - Plain Sheath (316SS)	1 - Fiberglass Insulation 842°F/450°C	0 - Stripped Ends	1 - Single	1 - Grounded	2 - 1/8"	1 - None
K - T/C	2 - Plain Sheath w/ FEP Coating	2 - Fiberglass Insulation w/ SS Flex Hose	1 - Leads With #6 Spade Lugs	2 - Dual	2 - Ungrounded	3 - 3/16"	2 - 45°
E - T/C	4 - Back Filled Sheath*	3 - Fiberglass Insulation w/ SS Overbraid	2 - Leads With #6 Spade Lugs 1/2 BX	3 - Exposed Tip	4 - 1/4"	4 - 1/4"	3 - 90°
T - T/C	5 - Back Filled Sheath w/ FEP Coating*	4 - FEP Insulation 392°F/200°C	3 - Standard Plug	5 - 3/8"			
	6 - Bayonet Mount Adjustable Length	5 - FEP Insulation w/ SS Overbraid	4 - Standard Jack				
	7 - Bayonet Mount Fixed Length	6 - FEP Insulation w/ FEP Coated Flex Hose	6 - Mini Plug				

**HEAD ASSEMBLY OPTIONS\* (3/4" NPT Conduit Connection)**

- E - Screw Cover Head, AL w/ No Process Connection
- F - Screw Cover Head, Plastic w/ No Process Connection
- G - Screw Cover Head, SS w/ No Process Connection
- H - Snap Cover Head, AL w/ No Process Connection
- I - Screw Cover Head, AL w/ 1/2" NPT Process Connection
- J - Screw Cover Head, Plastic w/ 1/2" NPT Process Connection
- K - Screw Cover Head, SS w/ 1/2" NPT Process Connection
- L - Snap Cover Head, AL w/ 1/2" NPT Process Connection
- M - Screw Cover Head, AL w/ 3/4" NPT Process Connection
- N - Screw Cover Head, Plastic w/ 3/4" Process Connection
- P - Screw Cover Head, SS w/ 3/4" Process Connection
- Q - Snap Cover Head, AL w/ 3/4" Process Connection

\*Options only available on Series 4 RTD's